

Surpahs® Natural Bamboo Monitor Raiser Stand User Manual

Model: XMBB-MS-002

Please read the entire instruction manual before using the product and then save it for future reference. We reserve the right for any errors in text or images and any necessary changes made to technical data. In the event of technical problems or other queries, please contact our Customer Services. This manual can also be downloaded through www.surpahs.com

About Product Code

Please find your **Product Code** on the **Customer Card** that comes in the package, and register your product for **extended warranty**.

PARTS LIST

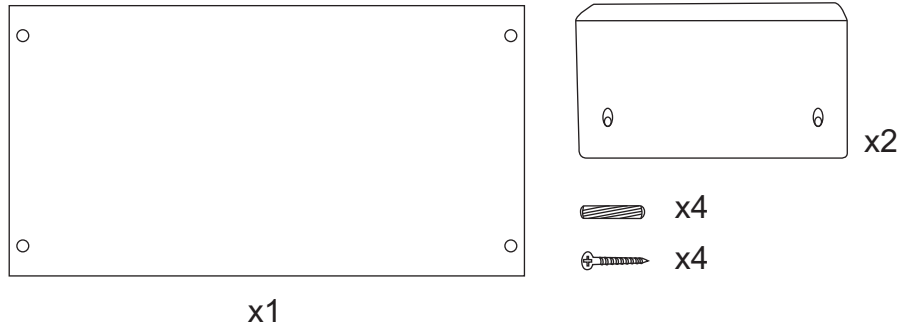

ASSEMBLY STEPS

STEP 1



WARRANTY

This product is warranted against defects in materials and workmanship for one year from the date purchase, when used in accordance with the instructions provided. This warranty does not cover damages or wear resulting from accident, misuse, abuse, commercial use, or unauthorized adjustment and/or repair.

C8KE INC. shall not be liable for loss of use or any other incidental, consequential or indirect costs, expenses or damages. There are no express warranties except as listed above. This warranty gives you specific legal rights, and you may have other rights which vary from state to state.

Should this product require service (or replacement at our option) while under warranty, please visit website www.surpahs.com and submit a support ticket.

Surpahs®, C8KE INC.
501 Silverside Rd, Suite 105
Wilmington, DE 19809, USA
www.surpahs.com

ASSEMBLY STEPS

STEP 2

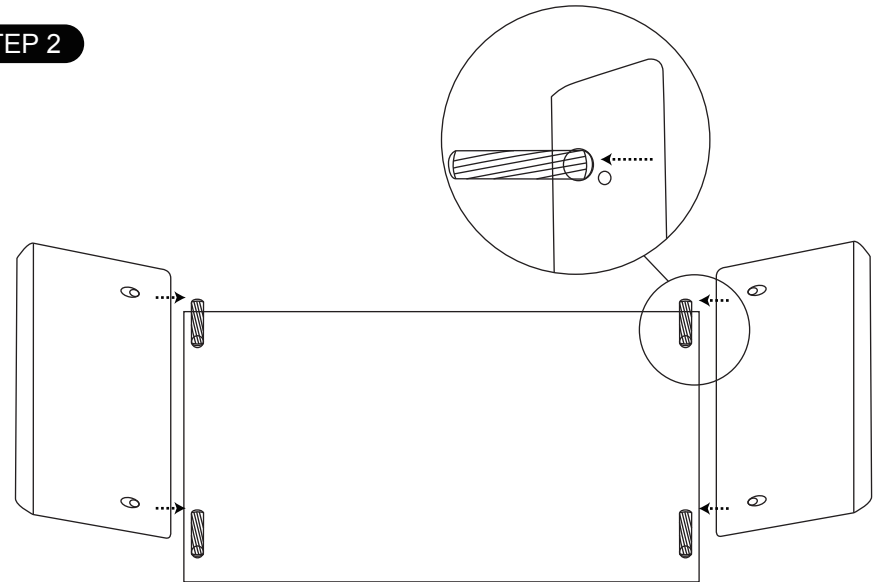

ASSEMBLY STEPS

STEP 3

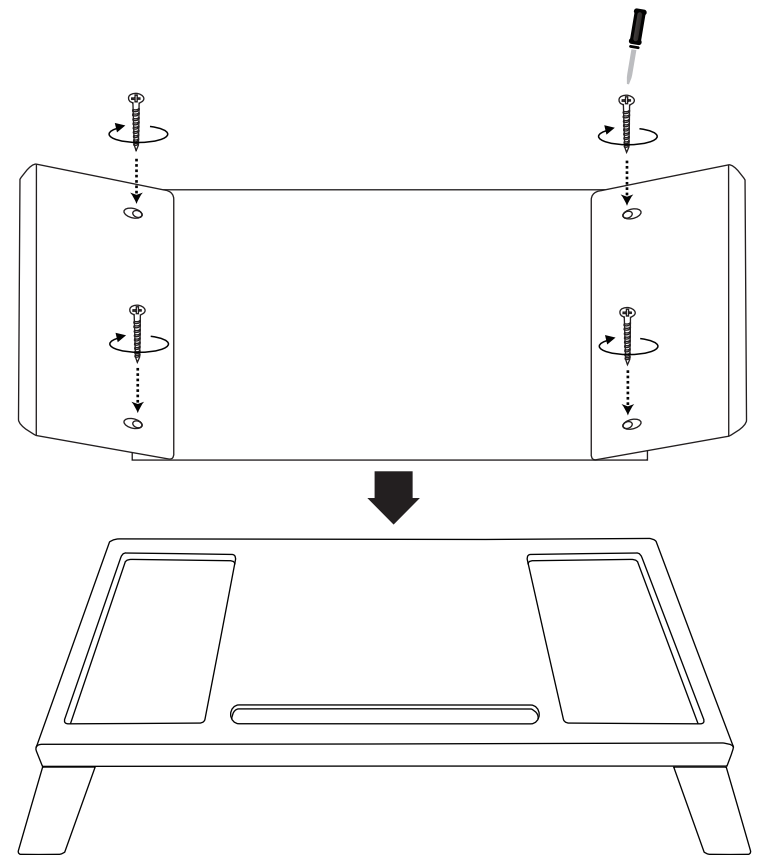

Scan for shopping
and support